

METAL OXIDE VARISTOR – 20D SERIES

FEATURES

- * Wide operating voltage (V1mA) range from 18V to 1800V.
- * Fast responding to transient over-voltage.
- * Large absorbing transient energy capability.
- * Low clamping ratio and no follow-on current.
- * Meets MSL level 1, per J-STD-020 ISO9001-2018
- * Safety number :  E317616 VDE-40028836 CQC-12001076476

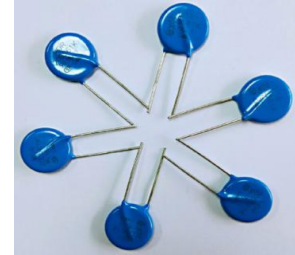

APPLICATION

- * Transistor, Diode, IC, Thyristor or Triac semiconductor protection.
- * Surge protection in consumer electronics.
- * Surge protection in industrial electronics.
- * Surge protection in electronic home appliances, gas and petroleum appliances.
- * Relay and electromagnetic valve surge absorption.



General Characteristics Definition

- * Operating Temperature: (-40 °C ~+85 °C) & (-40 °C ~+125 °C)
- * Storage Temperature: (-40 °C ~ +125 °C)
- * Working Surface Temperature: +115 °C
- * Insulation Resistance: > 100M Ω
- * Coating (Epoxy Resin): Flame-Retardant to UL 94 V-0



Material

- * Coating: Epoxy Resin
- * Lead Wire: The Copper Wire
- * Electrode: Silver Solder
- * Disk: Zinc Oxide

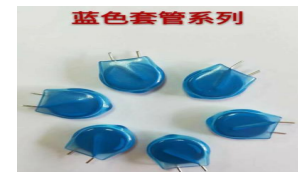

PART NUMBER CODE

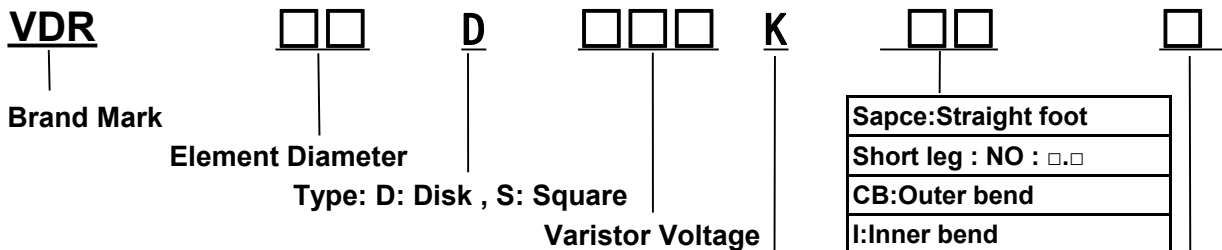

Sapce: Straight foot
Short leg : NO : □.□
CB: Outer bend
I: Inner bend
K: Small K foot
Y: High and low feet
J : High Surge
PH=Ultra Surge
TA : Ammo, TR : Reel
1□=Combinatorial wave
2□=Times
T & G is Horizontal patch

Tolerance : K±10%, L±15%

Sapce is 85°C
"H" is 125°C

Dimensions

S Type (Straight Lead)

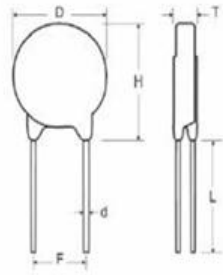

I Type (Inner Crimped Lead)

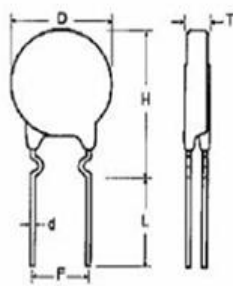

C Type (Out Crimped Lead)

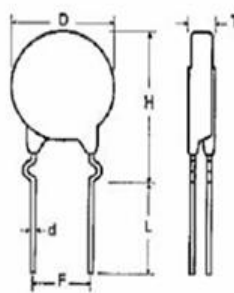

Y Lead Type (Y Kink Lead)

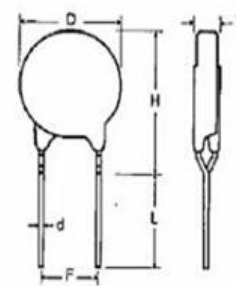

Unit: mm

Part No.	Part No.	T Max.	D Max.	H Max.		L min.	F	d ± 0.05
				S	I / C / Y			
VDR-20D180L	VDR-20D180LJ	4.5	23.0	26.5	28.0	20.0	7.5±0.8 10±1.0	0.8 1.0
VDR-20D220K	VDR-20D220KJ	4.6						
VDR-20D270K	VDR-20D270KJ	4.7						
VDR-20D330K	VDR-20D330KJ	4.9						
VDR-20D390K	VDR-20D390KJ	4.8						
VDR-20D470K	VDR-20D470KJ	4.9						
VDR-20D560K	VDR-20D560KJ	5.0						
VDR-20D680K	VDR-20D680KJ	5.2						
VDR-20D820K	VDR-20D820KJ	4.1						
VDR-20D101K	VDR-20D101KJ	4.3						
VDR-20D121K	VDR-20D121KJ	4.4						
VDR-20D151K	VDR-20D151KJ	4.2						
VDR-20D181K	VDR-20D181KJ	4.3						
VDR-20D201K	VDR-20D201KJ	4.4						
VDR-20D221K	VDR-20D221KJ	4.5						
VDR-20D241K	VDR-20D241KJ	4.6						
VDR-20D271K	VDR-20D271KJ	4.7						
VDR-20D301K	VDR-20D301KJ	4.8						
VDR-20D331K	VDR-20D331KJ	5.0						
VDR-20D361K	VDR-20D361KJ	5.2						
VDR-20D391K	VDR-20D391KJ	5.2						
VDR-20D431K	VDR-20D431KJ	5.4						
VDR-20D471K	VDR-20D471KJ	5.9						
VDR-20D511K	VDR-20D511KJ	6.1						
VDR-20D561K	VDR-20D561KJ	6.4						
VDR-20D621K	VDR-20D621KJ	6.8						
VDR-20D681K	VDR-20D681KJ	7.1						
VDR-20D751K	VDR-20D751KJ	7.2						
VDR-20D781K	VDR-20D781KJ	7.3						
VDR-20D821K	VDR-20D821KJ	7.5						
VDR-20D911K	VDR-20D911KJ	7.6						
VDR-20D102K	VDR-20D102KJ	8.0						
VDR-20D112K	VDR-20D112KJ	8.5						
VDR-20D122K	VDR-20D122KJ	9.0						
VDR-20D142K	VDR-20D142KJ	10.5						
VDR-20D162K	VDR-20D162KJ	11.0						
VDR-20D182K	VDR-20D182KJ	12.0						

ELECTRICAL CHARACTERISTIC

Part Number		Maximum Allowable Voltage		Varistor Voltage	Maximum Clamping Voltage		Withstanding Surge Current		Energy 10/1000µS		Rated Power	Typical Capacitance (Reference)
Standard	High Surge	AC (V)	DC (V)	V1mA(V)	IP(A)	VC(V)	I(A) Standard	I(A) High Surge	(J) Standard	(J) High Surge	(W)	@1KHzPF
20D180L	20D180LJ	11	14	18(15.3~20.7)	20	36	2000	3000	11	13	0.2	28500
20D220K	20D220KJ	14	18	22(19.8~24.2)	20	43	2000	3000	14	16	0.2	18500
20D270K	20D270KJ	17	22	27(24.3~29.7)	20	53	2000	3000	16	19	0.2	13000
20D330K	20D330KJ	20	26	33(29.7~36.3)	20	65	2000	3000	23	24	0.2	11500
20D390K	20D390KJ	25	31	39(35.1~42.9)	20	77	2000	3000	26	28	0.2	8500
20D470K	20D470KJ	30	38	47(42.3~51.7)	20	93	2000	3000	30	34	0.2	7400
20D560K	20D560KJ	35	45	56(50.4~61.6)	20	110	2000	3000	41	46	0.2	6500
20D680K	20D680KJ	40	56	68(61.2~74.8)	20	135	2000	3000	46	49	0.2	5800
20D820K	20D820KJ	50	65	82(73.8~90.2)	100	135	6500	10000	38	56	1.0	4900
20D101K	20D101KJ	60	85	100(90~110)	100	165	6500	10000	45	70	1.0	4000
20D121K	20D121KJ	75	100	120(108~132)	100	200	6500	10000	55	85	1.0	3300
20D151K	20D151KJ	95	125	150(135~165)	100	250	6500	10000	70	106	1.0	2700
20D181K	20D181KJ	115	150	180(162~198)	100	300	6500	10000	85	130	1.0	2200
20D201K	20D201KJ	130	170	200(185~225)	100	330	6500	10000	95	140	1.0	2000
20D221K	20D221KJ	140	180	220(198~242)	100	360	6500	10000	100	155	1.0	1800
20D241K	20D241KJ	150	200	240(216~264)	100	395	6500	10000	108	168	1.0	1650
20D271K	20D271KJ	175	225	270(243~297)	100	455	6500	10000	127	190	1.0	1500
20D301K	20D301KJ	190	250	300(270~330)	100	505	6500	10000	136	210	1.0	1300
20D331K	20D331KJ	210	275	330(297~363)	100	550	6500	10000	150	228	1.0	1200
20D361K	20D361KJ	230	300	360(324~396)	100	595	6500	10000	163	255	1.0	1100
20D391K	20D391KJ	250	320	390(351~429)	100	650	6500	10000	180	275	1.0	1000
20D431K	20D431KJ	275	350	430(387~473)	100	710	6500	10000	190	305	1.0	930
20D471K	20D471KJ	300	385	470(423~517)	100	775	6500	10000	220	350	1.0	850
20D511K	20D511KJ	320	415	510(459~561)	100	845	6500	10000	225	360	1.0	780
20D561K	20D561KJ	350	460	560(504~616)	100	920	6500	10000	230	380	1.0	710
20D621K	20D621KJ	385	505	620(558~682)	100	1025	6500	10000	235	390	1.0	650
20D681K	20D681KJ	420	560	680(612~748)	100	1120	6500	10000	240	400	1.0	600
20D751K	20D751KJ	460	615	750(675~825)	100	1240	6500	10000	255	420	1.0	530
20D781K	20D781KJ	485	640	780(702~858)	100	1290	6500	10000	265	440	1.0	510
20D821K	20D821KJ	510	670	820(738~902)	100	1355	6500	10000	282	460	1.0	500
20D911K	20D911KJ	550	745	910(819~1001)	100	1500	6500	10000	310	510	1.0	440
20D102K	20D102KJ	625	825	1000(900~1100)	100	1650	6500	10000	342	565	1.0	400
20D112K	20D112KJ	680	895	1100(990~1210)	100	1815	6500	10000	383	620	1.0	360
20D122K	20D122KJ	750	990	1200(1080~1320)	100	1980	6500	10000	408	660	1.0	350
20D142K	20D142KJ	880	1140	1400(1260~1540)	100	2310	6500	10000	532	784	1.0	340
20D162K	20D162KJ	1000	1280	1600(1400~1760)	100	2640	6500	10000	606	896	1.0	330
20D182K	20D182KJ	1100	1465	1800(1620~1980)	100	2970	6500	10000	625	990	1.0	320

20D180L & 20D220K does not have VDE certification

Reliability Test

Mechanical Ratings

Test Parameter	Test Condition / Description			Performance Requirements
Terminal Pull Strength	After gradually applying the load specified below and keeping the unit fixed for ten seconds, the terminal shall be visually examined for any damage.	Diameter	Loading	No visible damage
		0.6mm	1.0 Kg	
		0.8mm	1.0 Kg	
		1.0mm	2.0 Kg	
Terminal Bending Strength	The unit shall be secured with its terminal kept vertical and the weight specified below be applied in the axial direction. The terminal shall gradually be bent by 90° in one direction, then 90° in the opposite direction, and again back to the original position. The damage of the terminal shall be visually examined.	Diameter	Loading	No visible damage
		0.6mm	0.5 Kg	
		0.8mm	0.5 Kg	
		1.0mm	1.0 Kg	
Vibration	The Specimen shall be vibrated by its lead wires with a total amplitude of 1.5mm and a varying frequency of 10~55~10HZ(each minutes) for a period of 2 hours respectively in each X,Y and Z directions.			No visible damage $\Delta VB/VB\% \leq \pm 5\%$
Soldering-solderability	After dipping the terminal to depth of approximately 3mm from the specimen in a soldering bath of 260°C for 10±1(D5: 5±1) seconds. Thereafter the terminal shall be visually examined.			Terminations shall be uniformly tinned
Soldering-Resistance to Solder Heat	After preheating the specimen, the specimen shall be completely immersed into a soldering bath having a temperature of 260±5°C for 10±1 (D5: 5±1) seconds or iron of 400±5°C for 3±0.5 seconds. There after the change of Vb and mechanical damage shall be examined.			No visible damage $\Delta VB/VB\% \leq \pm 5\%$

ENVIRONMENTAL RATINGS

Dry Heat Loading	The specimen shall be applied continuously the maximum allowable voltage at the specified conditions for specified period and then stored at room temperature and normal humidity over 2 hours. Thereafter, the change of Vb and mechanical damage shall be examined. Ambient temp : 125±2°C ; Period : 1000±24hours.			$\Delta VB/VB\% \leq \pm 10\%$	
High Temperature Storage	In a drying oven without load. Ambient temp : 125±2°C ; period : 1000±24hours			$\Delta VB/VB\% \leq \pm 5\%$	
Damp Heat Loading	The specimen shall be applied continuously the maximum allowable voltage at the specified conditions for specified period and then stored at room temperature and normal humidity over 2 hours. Thereafter, the change of Vb and mechanical damage shall be examined. Ambient condition : 40±2°C , 90 to 95%R.H. ; period : 1000±24 hours			$\Delta VB/VB\% \leq \pm 10\%$	
Temperature Cycle	Condition the specimen to each temperature form step 1 to step 4 in this order for the period shown in the table of specifications. The change of Vb and mechanical damage shall be examined after 2 hours.	Step	Temp°C	Period	No visible damage $\Delta VB/VB\% \leq \pm 10\%$
		1	-40±3°C	30 min.	
		2	Room Temp	15 min.	
		3	85±2°C	30 min.	
		4	Room Temp	15 min.	
Surge Lifetime Rating	The change of Vb shall be measured after the impulse listed below is applied 10,000 times continuously with the interval of ten seconds at room temperature.			No visible damage $\Delta VB/VB\% \leq \pm 10\%$	
Voltage Proof	Voltage : 2500VAC Leakage Current ≤ 0.5mA Time : 60 Seconds			No Breakdown	

MARKING CODE

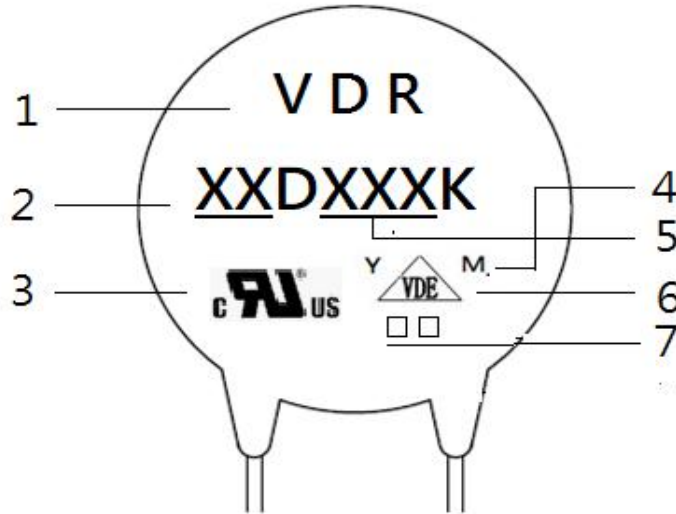

- 1 Logo
- 2 Disk Size
- 3  Accreditation Logo
- 4 “Y” & “M” Product Line Code
- 5 Varistor Voltage
- 6 VDE Accreditation Logo
- 7 “J” is High Surge Code, not “J” is Standard Surge
“H” is High temperature range, not “H” is Standard

Packaging specification / bulk packaging quantity

Unit:Pcs

Dimension	Part No.	Bag	Small Carton	Carton
20D	180L to 112K	250	1,500	3,000
20D (Short leg)	180L to 112K	250	2,000	4,000

Taping and Dimensions (20D)

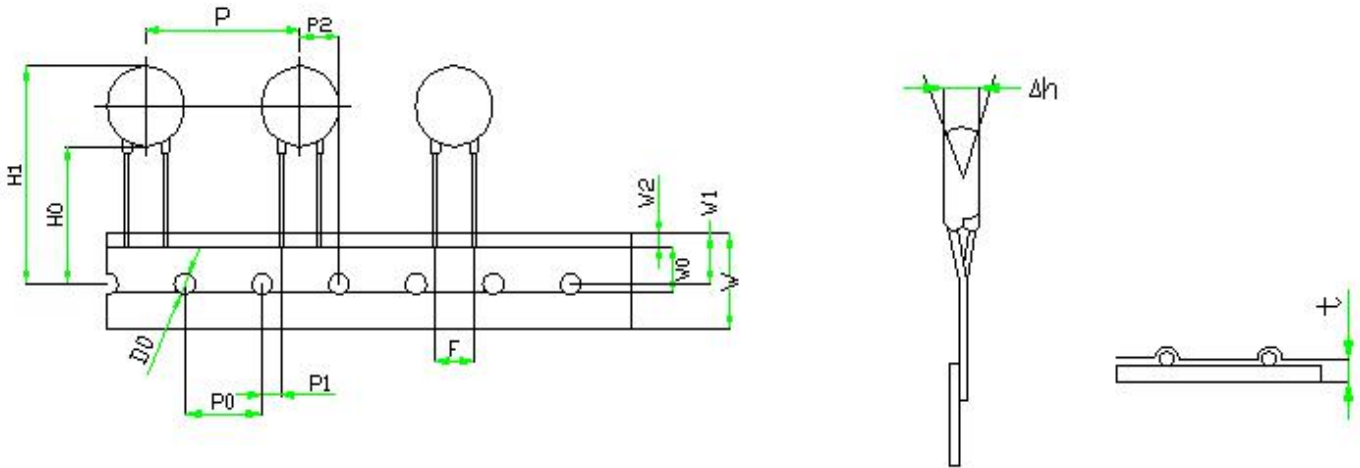

ITEM.	P	P0	P1	P2	F	Δh	W	W0	W1	W2	H1	H0	Do	t
Ø0.8mm	25.4	12.7	2.6	8.95	7.5	0	18	8	9	3	46.5	20	4	0.6
7.5mm	±1.0	±0.3	±0.5	±1.3	±0.8	±0.5	±0.8	±1.0	±0.5	Max	Max	Max	±0.2	±0.3
Ø1.0mm	25.4	12.7	2.6	7.7	10.0	0	18	8	9	3	46.5	20	4	0.6
F10.0mm	±1.0	±0.3	±0.5	±1.3	±0.8	±0.5	±0.8	±1.0	±0.5	Max	Max	Max	±0.2	±0.3

(Unit:mm)

Packaging

■ **Reel Packing**

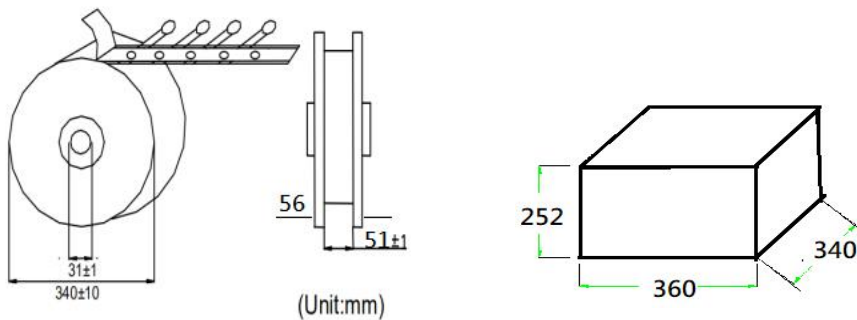

(Unit:mm)

Disc Size/mm	pcs/reel
Φ 05/07(180~391)	1500
Φ 05/07(431~821)	1000
Φ 10(180~391)	1000
Φ 10(431~911)	750
Φ 10(102~112)	500
Φ 14(180~391)	750
Φ 14(431~112)	500
Φ 20(180~681)	300
Φ 20(751~112)	250

4 Reels/ Carton

■ **Ammo Packing**

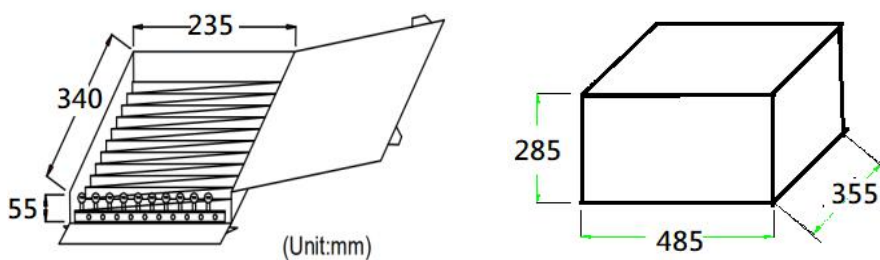

(Unit:mm)

Disc Size/mm	pcs/ box
Φ 05/07(180~821)	1000
Φ 10(181~361)	750
Φ 10(391~621)	400
Φ 10(681~112)	300
Φ 14(181~271)	500
Φ 14(301~112)	250
Φ 20(180~681)	300
Φ 20(751~112)	250

10 Boxes/Carton