

METAL OXIDE VARISTOR – 10D SERIES

FEATURES

- * Wide operating voltage (V1mA) range from 18V to 1100V.
- * Fast responding to transient over-voltage.
- * Large absorbing transient energy capability.
- * Low clamping ratio and no follow-on current.
- * Meets MSL level 1, per J-STD-020 ISO9001-2018
- * Safety number :  US E317616 VDE-40028836 CQC-12001076479

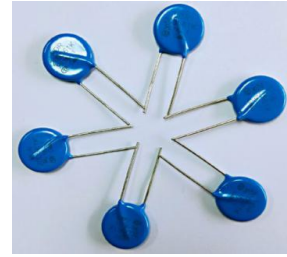

APPLICATION

- * Transistor, Diode, IC, Thyristor or Triac semiconductor protection.
- * Surge protection in consumer electronics.
- * Surge protection in industrial electronics.
- * Surge protection in electronic home appliances, gas and petroleum appliances.
- * Relay and electromagnetic valve surge absorption.



General Characteristics Definition

- * Operating Temperature: (-40 °C ~+85 °C) & (-40 °C ~+125 °C)
- * Storage Temperature: (-40 °C ~ +125 °C)
- * Working Surface Temperature: +115 °C
- * Insulation Resistance: > 100M Ω
- * Coating (Epoxy Resin): Flame-Retardant to UL 94 V-0



Material

- * Coating: Epoxy Resin
- * Lead Wire: The Copper Wire
- * Electrode: Silver Solder
- * Disk: Zinc Oxide

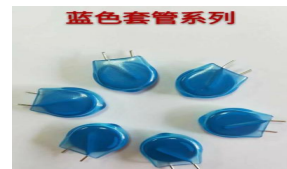

PART NUMBER CODE

VDR □□ **D** □□□ **K** □□ □

Brand Mark Element Diameter Type: D: Disk , S: Square Varistor Voltage

Sapce: Straight foot
Short leg : NO : □.□
CB: Outer bend
I: Inner bend
K: Small K foot
Y: High and low feet
J : High Surge
PH=Ultra Surge
TA : Ammo, TR : Reel
1□=Combinatorial wave
2□=Times
T & G is Horizontal patch

Tolerance : K±10%, L±15%

Sapce is 85°C
"H" is 125°C

Dimensions

S Type(Straight Lead)

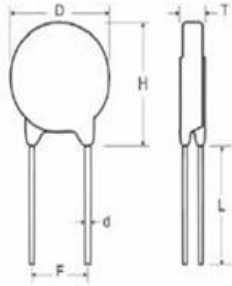

I Type(Inner Crimped Lead)

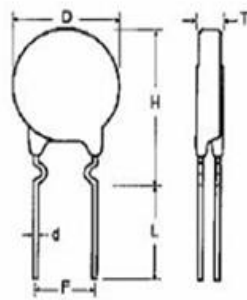

C Type(Out Crimped Lead)

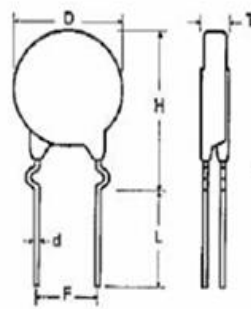

Y Lead Type(Y Kink Lead)

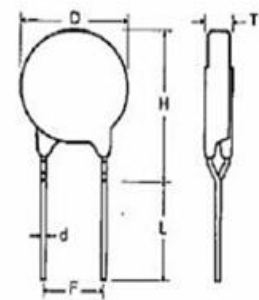

Unit: mm

Part No.	Part No.	T Max.	D Max.	H Max.		L min.	F ±0.8	d ± 0.05
				S	I / C / Y			
VDR-10D180L	VDR-10D180LJ	4.5	12.5	16.5	17.5	20.0	7.5	0.8
VDR-10D220K	VDR-10D220KJ	4.6						
VDR-10D270K	VDR-10D270KJ	4.7						
VDR-10D330K	VDR-10D330KJ	4.9						
VDR-10D390K	VDR-10D390KJ	4.8						
VDR-10D470K	VDR-10D470KJ	4.9						
VDR-10D560K	VDR-10D560KJ	5.0						
VDR-10D680K	VDR-10D680KJ	5.2						
VDR-10D820K	VDR-10D820KJ	4.1						
VDR-10D101K	VDR-10D101KJ	4.3						
VDR-10D121K	VDR-10D121KJ	4.5						
VDR-10D151K	VDR-10D151KJ	4.8						
VDR-10D181K	VDR-10D181KJ	4.3						
VDR-10D201K	VDR-10D201KJ	4.4						
VDR-10D221K	VDR-10D221KJ	4.5						
VDR-10D241K	VDR-10D241KJ	4.6						
VDR-10D271K	VDR-10D271KJ	4.9						
VDR-10D301K	VDR-10D301KJ	5.0						
VDR-10D331K	VDR-10D331KJ	5.1						
VDR-10D361K	VDR-10D361KJ	5.2						
VDR-10D391K	VDR-10D391KJ	5.4						
VDR-10D431K	VDR-10D431KJ	5.7						
VDR-10D471K	VDR-10D471KJ	6.0						
VDR-10D511K	VDR-10D511KJ	6.2						
VDR-10D561K	VDR-10D561KJ	6.5						
VDR-10D621K	VDR-10D621KJ	7.1						
VDR-10D681K	VDR-10D681KJ	7.6						
VDR-10D751K	VDR-10D751KJ	8.0						
VDR-10D781K	VDR-10D781KJ	8.1						
VDR-10D821K	VDR-10D821KJ	8.3						
VDR-10D911K	VDR-10D911KJ	8.8						
VDR-10D102K	VDR-10D102KJ	9.3						
VDR-10D112K	VDR-10D112KJ	9.9						

ELECTRICAL CHARACTERISTIC

Part Number		Maximum Allowable Voltage		Varistor Voltage	Maximum Clamping Voltage		Withstanding Surge Current		Energy 10/1000 μ S		Rated Power	Typical Capacitance (Reference)
Standard	High Surge	AC (V)	DC (V)	V1mA(V)	IP(A)	VC(V)	I(A) Standard	I(A) High Surge	(J) Standard	(J) High Surge	(W)	@1KHzPF
10D180L	10D180LJ	11	14	18(15.3~20.7)	5	36	500	1000	2.1	3	0.05	5600
10D220K	10D220KJ	14	18	22(19.8~24.2)	5	43	500	1000	2.5	5	0.05	4500
10D270K	10D270KJ	17	22	27(24.3~29.7)	5	53	500	1000	3.0	6	0.05	3700
10D330K	10D330KJ	20	26	33(29.7~36.3)	5	65	500	1000	4.0	7	0.05	3000
10D390K	10D390KJ	25	31	39(35.1~42.9)	5	77	500	1000	4.6	9	0.05	2400
10D470K	10D470KJ	30	38	47(42.3~51.7)	5	93	500	1000	5.5	11	0.05	2100
10D560K	10D560KJ	35	45	56(50.4~61.6)	5	110	500	1000	7.0	13	0.05	1800
10D680K	10D680KJ	40	56	68(61.2~74.8)	5	135	500	1000	8.2	15	0.05	1500
10D820K	10D820KJ	50	65	82(73.8~90.2)	25	135	2500	3500	12	17	0.4	1200
10D101K	10D101KJ	60	85	100(90~110)	25	165	2500	3500	15	18	0.4	1000
10D121K	10D121KJ	75	100	120(108~132)	25	200	2500	3500	18	21	0.4	830
10D151K	10D151KJ	95	125	150(135~165)	25	250	2500	3500	22	25	0.4	670
10D181K	10D181KJ	115	150	180(162~198)	25	300	2500	3500	27	30	0.4	560
10D201K	10D201KJ	130	170	200(185~225)	25	330	2500	3500	30	35	0.4	500
10D221K	10D221KJ	140	180	220(198~242)	25	360	2500	3500	32	39	0.4	450
10D241K	10D241KJ	150	200	240(216~264)	25	395	2500	3500	35	42	0.4	420
10D271K	10D271KJ	175	225	270(243~297)	25	455	2500	3500	37	49	0.4	370
10D301K	10D301KJ	190	250	300(270~330)	25	505	2500	3500	40	54	0.4	330
10D331K	10D331KJ	210	275	330(297~363)	25	550	2500	3500	43	58	0.4	300
10D361K	10D361KJ	230	300	360(324~396)	25	595	2500	3500	47	65	0.4	280
10D391K	10D391KJ	250	320	390(351~429)	25	650	2500	3500	60	70	0.4	260
10D431K	10D431KJ	275	350	430(387~473)	25	710	2500	3500	65	80	0.4	230
10D471K	10D471KJ	300	385	470(423~517)	25	775	2500	3500	67	85	0.4	210
10D511K	10D511KJ	320	415	510(459~561)	25	845	2500	3500	69	90	0.4	200
10D561K	10D561KJ	350	460	560(504~616)	25	920	2500	3500	70	92	0.4	180
10D621K	10D621KJ	385	505	620(558~682)	25	1025	2500	3500	72	95	0.4	160
10D681K	10D681KJ	420	560	680(612~748)	25	1120	2500	3500	75	98	0.4	150
10D751K	10D751KJ	460	615	750(675~825)	25	1240	2500	3500	77	100	0.4	140
10D781K	10D781KJ	485	640	780(702~858)	25	1290	2500	3500	80	105	0.4	130
10D821K	10D821KJ	510	670	820(738~902)	25	1355	2500	3500	85	110	0.4	120
10D911K	10D911KJ	550	745	910(819~1001)	25	1500	2500	3500	93	130	0.4	110
10D102K	10D102KJ	625	825	1000(900~1100)	25	1650	2500	3500	102	140	0.4	100
10D112K	10D112KJ	680	895	1100(990~1210)	25	1815	2500	3500	115	150	0.4	90

Reliability Test

Mechanical Ratings

Test Parameter	Test Condition / Description			Performance Requirements
Terminal Pull Strength	After gradually applying the load specified below and keeping the unit fixed for ten seconds, the terminal shall be visually examined for any damage.	Diameter	Loading	No visible damage
		0.6mm	1.0 Kg	
		0.8mm	1.0 Kg	
		1.0mm	2.0 Kg	
Terminal Bending Strength	The unit shall be secured with its terminal kept vertical and the weight specified below be applied in the axial direction. The terminal shall gradually be bent by 90° in one direction, then 90° in the opposite direction, and again back to the original position. The damage of the terminal shall be visually examined.	Diameter	Loading	No visible damage
		0.6mm	0.5 Kg	
		0.8mm	0.5 Kg	
		1.0mm	1.0 Kg	
Vibration	The Specimen shall be vibrated by its lead wires with a total amplitude of 1.5mm and a varying frequency of 10~55~10HZ(each minutes) for a period of 2 hours respectively in each X,Yand Z directions.			No visible damage $\Delta VB/VB\% \leq \pm 5\%$
Soldering-solderability	After dipping the terminal to depth of approximately 3mm from the specimen in a soldering bath of 260°C for 10±1(D5: 5±1) seconds. Thereafter the terminal shall be visually examined.			Terminations shall be uniformly tinned
Soldering-Resistance to Solder Heat	After preheating the specimen, the specimen shall be completely immersed into a soldering bath having a temperature of 260±5°C for 10±1 (D5: 5±1) seconds or iron of 400±5°C for 3±0.5 seconds. There after the change of Vb and mechanical damage shall be examined.			No visible damage $\Delta VB/VB\% \leq \pm 5\%$

ENVIRONMENTAL RATINGS

Dry Heat Loading	The specimen shall be applied continuously the maximum allowable voltage at the specified conditions for specified period and then stored at room temperature and normal humidity over 2 hours. Thereafter, the change of Vb and mechanical damage shall be examined. Ambient temp : 125±2°C ; Period : 1000±24hours.			$\Delta VB/VB\% \leq \pm 10\%$	
High Temperature Storage	In a drying oven without load. Ambient temp : 125±2°C ; period : 1000±24hours			$\Delta VB/VB\% \leq \pm 5\%$	
Damp Heat Loading	The specimen shall be applied continuously the maximum allowable voltage at the specified conditions for specified period and then stored at room temperature and normal humidity over 2 hours. Thereafter, the change of Vb and mechanical damage shall be examined. Ambient condition : 40±2°C , 90 to 95%R.H. ; period : 1000±24 hours			$\Delta VB/VB\% \leq \pm 10\%$	
Temperature Cycle	Condition the specimen to each temperature form step 1 to step 4 in this order for the period shown in the table of specifications. The change of Vb and mechanical damage shall be examined after 2 hours.	Step	Temp°C	No visible damage $\Delta VB/VB\% \leq \pm 10\%$	
		1	-40±3°C		30 min.
		2	Room Temp		15 min.
		3	85±2°C		30 min.
4	Room Temp	15 min.			
Surge Lifetime Rating	The change of Vb shall be measured after the impulse listed below is applied 10,000 times continuously with the interval of ten seconds at room temperature.			No visible damage $\Delta VB/VB\% \leq \pm 10\%$	
Voltage Proof	Voltage : 2500VAC Leakage Current ≤ 0.5mA Time : 60 Seconds			No Breakdown	

MARKING CODE

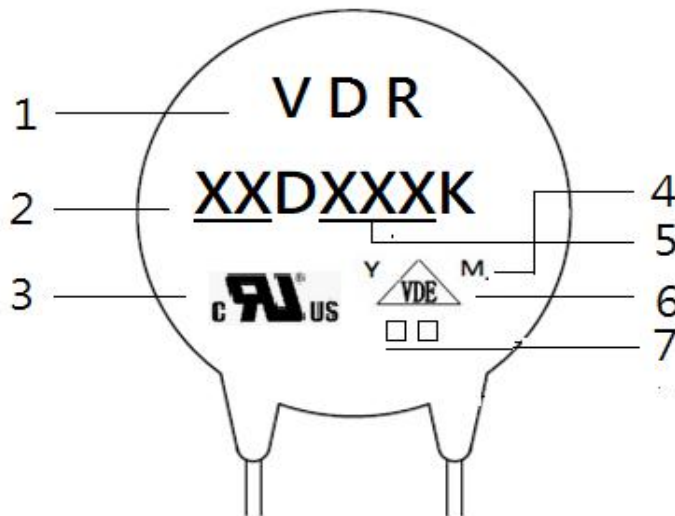

- 1 Logo
- 2 Disk Size
- 3  Accreditation Logo
- 4 “Y” & “M” Product Line Code
- 5 Varistor Voltage
- 6 VDE Accreditation Logo
- 7 “J” is High Surge Code, not “J” is Standard Surge
“H” is High temperature range, not “H” is Standard

Packaging specification / bulk packaging quantity

Unit:Pcs

Dimension	Part No.	Bag	Small Carton	Carton
10D	180L to 112K	500	5,000	10,000
10D (Short leg)	180L to 112K	500	7,500	15,000

Taping and Dimensions (10D)

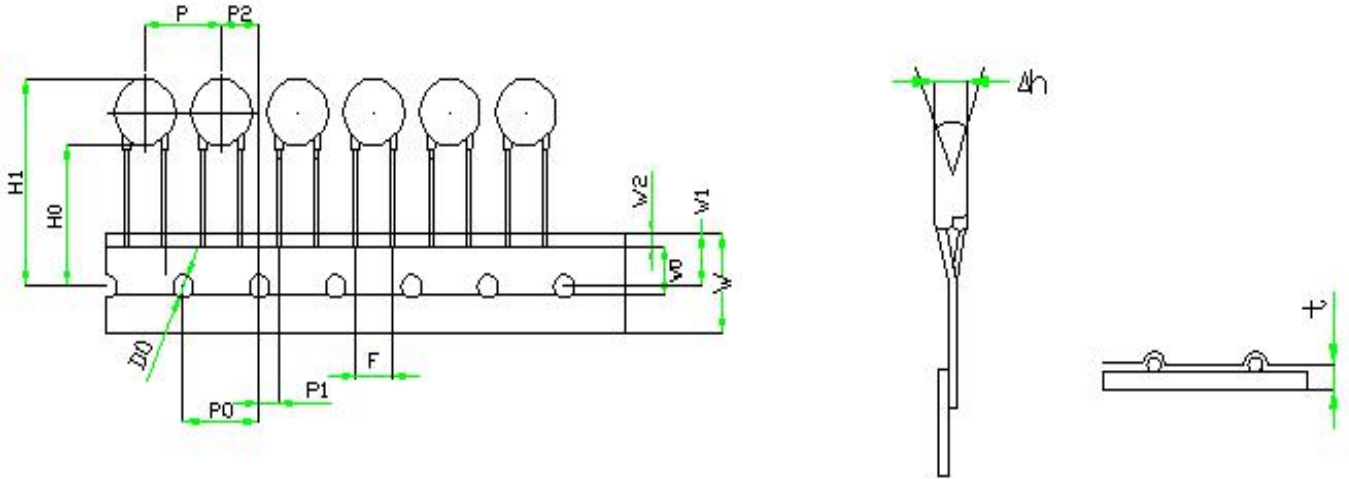

ITEM.	P	P0	P1	P2	F	Δh	W	W0	W1	W2	H1	H0	Do	t
ToL.	12.7	12.7	2.6	6.35	7.5	0	18	8	9	3	35	20	4	0.4
Nor.	±1.0	±0.3	±0.5	±1.3	±0.8	±0.5	±0.8	±1.0	±0.5	Max	Max	±1.0	±0.2	±0.3

(Unit:mm)

Packaging

■ Reel Packing

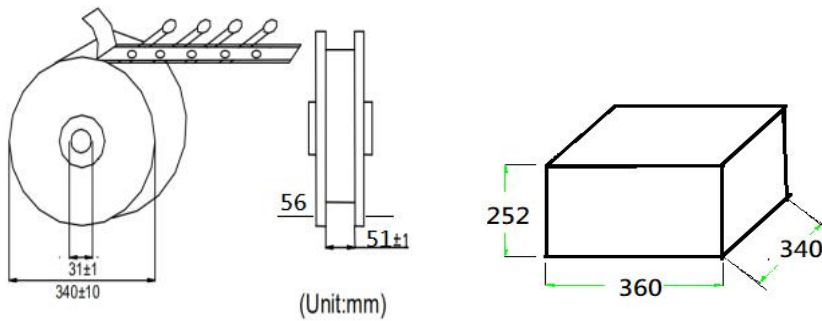

4 Reels/ Carton

Disc Size/mm	pcs/reel
Φ 05/07(180~391)	1500
Φ 05/07(431~821)	1000
Φ 10(180~391)	1000
Φ 10(431~911)	750
Φ 10(102~112)	500
Φ 14(180~391)	750
Φ 14(431~112)	500
Φ 20(180~681)	500
Φ 20(751~112)	250

■ Ammo Packing

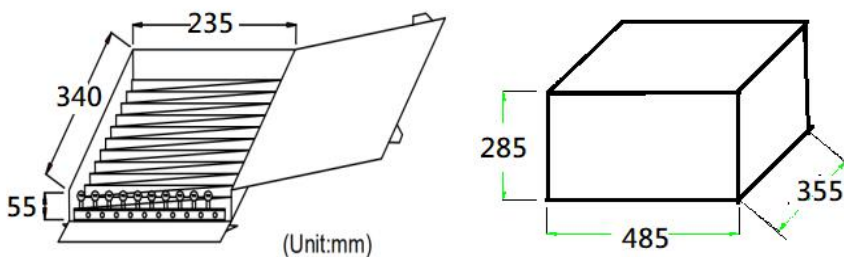

10 Boxes/Carton

Disc Size/mm	pcs/ box
Φ 05/07(180~821)	1000
Φ 10(181~361)	750
Φ 10(391~621)	400
Φ 10(681~112)	300
Φ 14(181~271)	500
Φ 14(301~112)	250